

Battery Booster 12

9V battery eliminator for the Mini SSC II
Manual Revision 1.2

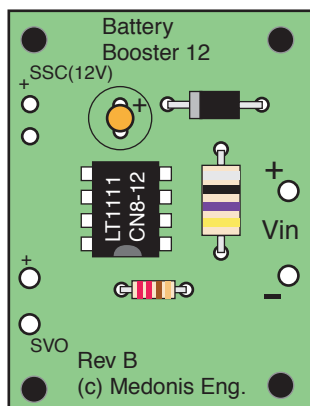

Battery Booster 12

What is it?

The Battery Booster 12 is a DC-DC converter that outputs 12 volts from a 2-6 volt input. Either a four cell battery pack or a 5V DC power supply will work.

- Runs Mini SSC II and servos from same battery pack. Eliminates 9V battery, simplifies wiring, and streamlines battery charging.
- Mounts directly underneath Mini SSC II with included hardware – adding the Battery Booster 12 is a quick and easy upgrade to your robot.

The Battery Booster 12 is assembled and tested, however soldering is required to connect the Battery Booster 12 to the Mini SSC II.

Medonis Engineering

282 SW 105th Ter
Portland, OR 97225 USA
Tel 503-860-1980 • Fax 503-641-3427
www.medonis.com
info@medonis.com

Instructions for the Battery Booster 12

The Battery Booster 12 is a DC-DC converter that outputs 12 volts from a 2.0 to 6.0 volt input. Designed to mount directly underneath the Mini SSC II serial servo controller from Scott Edwards Electronics, the Battery Booster 12 eliminates the 9V battery and allows the Mini SSC II to run from the same four cell battery pack as the servos. This simplifies wiring and battery charging problems.

As the voltage output from your battery pack drops, the Battery Booster keeps the Mini SSC II running. The range of input voltage allows using alkaline, NiCad, NiMH, or rechargeable alkaline batteries. Alternatively, you can also use an AC power supply with a 5Vdc output. Just be sure it has enough current so that you get the full torque from your servos.

The Battery Booster 12 shape and mounting hole locations were designed for mounting directly underneath the Mini SSC II using the included mounting hardware. The Battery Booster 12 eliminates the need for a 9V battery or 8-15 V power supply for the logic on the Mini SSC II, which saves weight and money.

Attaching the Battery Booster 12 to the Mini SSC II

The Battery Booster 12 circuit board ships assembled and tested, and the circuit needs no adjustment.

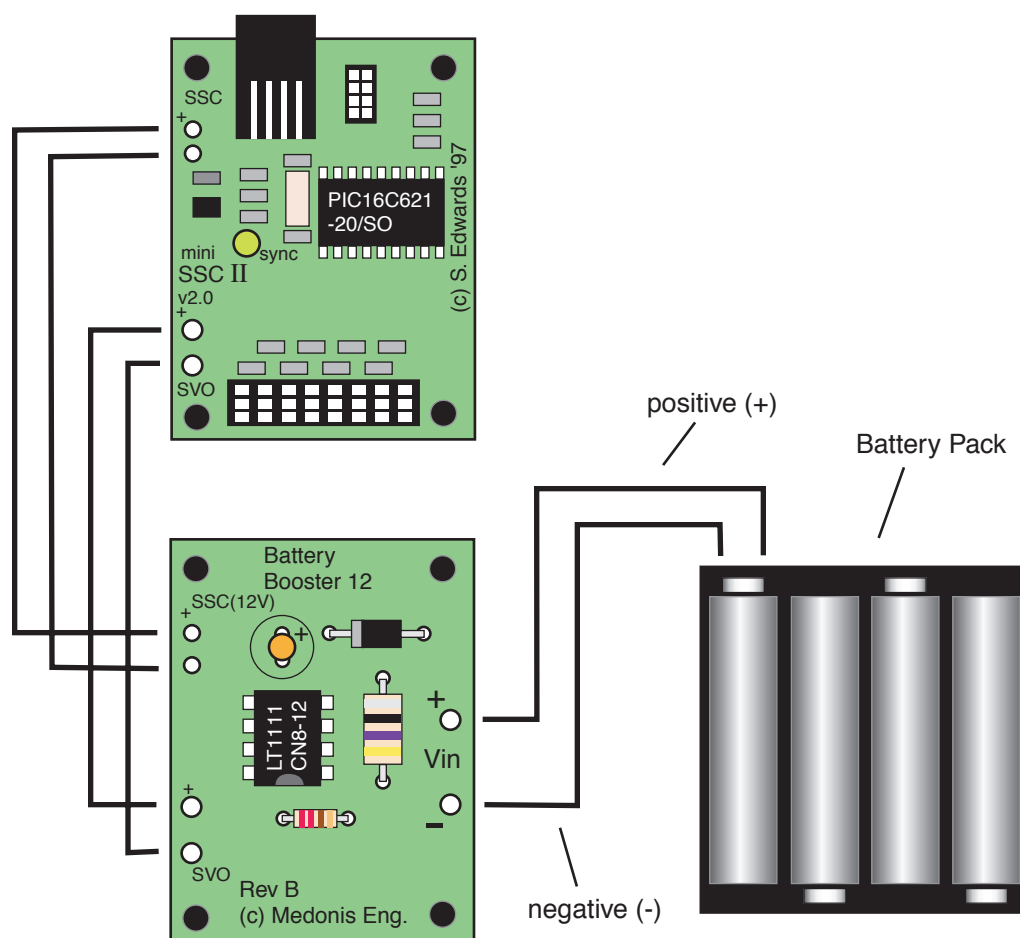

The Mini SSC II power wires must be soldered to the terminals on the Battery Booster 12. Cut the power wires on the Mini SSC II to about 1 1/2 inches in length, long enough to reach the Battery Booster 12 mounted below the Mini SSC II. Strip the ends of the wires, and solder them into the terminals on the Battery Booster 12. The terminals are located so they are the same locations and pattern as those on the Mini SSC II. Connect the wires from your battery pack to the Volts In terminals labeled Vin. The Vin terminal holes will fit up to 18-gauge wire.

Mechanical Mounting

The Battery Booster 12 mounts just below the Mini SSC II using a tubular aluminum spacer, a 1/2 inch long 4/40 screw, and a hex threaded spacer. The hex threaded spacer is 1/4 inch across the flats, so you can use a wrench in this size or pliers. Use the 1/2 inch long screw to attach the two boards together, tightening the hex threaded spacer at the bottom as shown in the figure below:

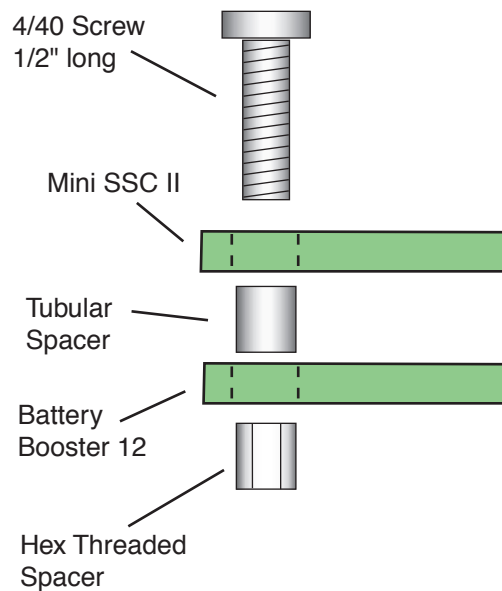

The 1/4" long 4-40 thread screws are used to attach the Mini SSC II / Battery Booster 12 assembly to a baseplate on your robot or animatronic. Here are the dimensions of the Battery Booster 12/Mini SSC II mounting holes:

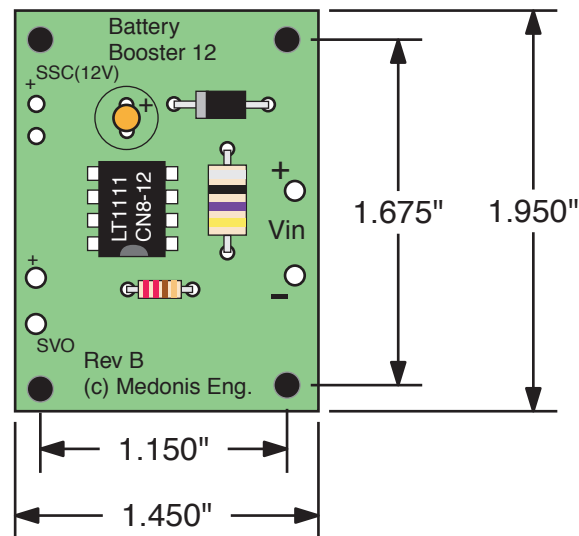

Note: 1.675" = 1 11/16" and 1.150" = 1 5/32"

Circuit Description

The Battery Booster 12 electronic module is a Step-Up DC-DC Converter. This Step-Up of the 2-6 volt input into a 12 volt output is accomplished with an integrated circuit from Linear Technology. This IC switches the SW1 pin to ground and open again, at 72 kHz, and this cycling of current through inductor L1 causes the output voltage to rise. The diode D1 keeps the output voltage positive, and the capacitor C1 minimizes the ripple in the output voltage to less than 125mV.

The circuit converts input voltages between 2.0 and 6.0 volts into a regulated 12.0 volt output. The Booster output is capable of supplying up to 15mA of output current. The output voltage does ripple a small amount, about 125mV (0.125 volts) at maximum 15mA current draw. Lower current draw reduces the voltage ripple. Since the Mini SSC II is a digital circuit, and is regulating its supply voltage with its own circuitry, the small ripple from the Battery Booster 12 is not a problem.

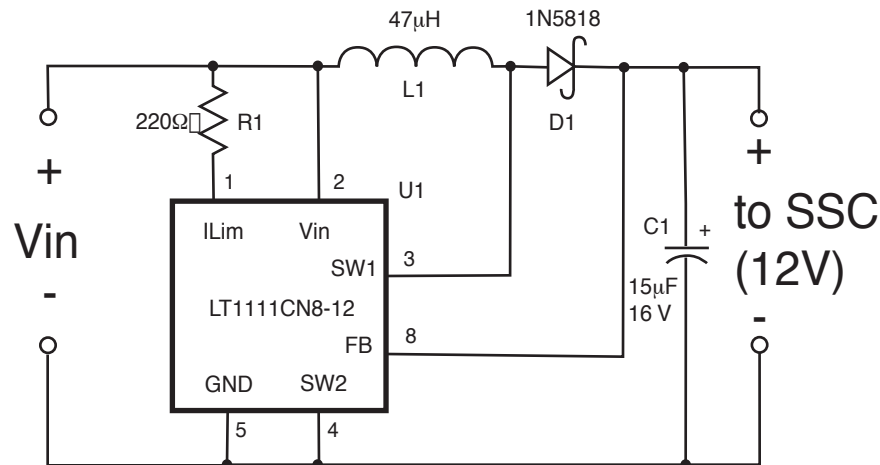

The Battery Booster 12 circuit is tested before shipment. However, if the circuit doesn't work, if any components are missing from the package, or if you have any questions:

Medonis Engineering

282 SW 105th TERR

Portland, OR 97225

Tel (503) 860-1980

Fax (503) 641-3427

info@medonis.com

You can also surf over to the Medonis Engineering web site at:

<http://www.medonis.com>

Copyright © Medonis Engineering 2003